

The high performance 1500DP creates a revolutionary concept in automated foodservice equipment. With Thermodyne's 1500DP, it is now possible to refrigerate, automatically reheat and hold prepared foods, with no food service attendant required. The 1500DP can be custom programmed for different meal times for every day of the week.

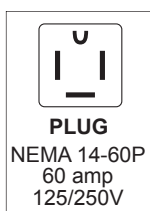

| SPECIFICATIONS | |
|---------------------------|-----------------------------|
| EXTERIOR DIMENSIONS | 35.00"W x 29.56"D x 74.50"H |
| INTERIOR DIMENSIONS | 26.50"W x 25.00"D x 45.50"H |
| CUBIC CAPACITY | 17.44ft ³ |
| MIN OPERATING TEMP | 36°F |
| MAX OPERATING TEMP | 230°F |
| NET WEIGHT | 583lbs. |
| SHIPPING WEIGHT | 660lbs. |
| ELECTRICAL SPECIFICATIONS | |
| VOLTS | 208 / 240 |
| AMPS | 52 / 59 |
| TOTAL WATTS | 10688 / 14250 |
| HERTZ | 50 / 60 |
| PHASE | 1 |
| PLUG | NEMA 14-60P |
| SHELVES | |
| STANDARD | 10 |
| CAPACITIES | |
| SHEET PAN | |
| 18" x 26" x 1" | 10 |
| STEAM TABLE PAN | |
| 12" x 20" x 2.5" | 20 |

Specifications subject to change without notice.

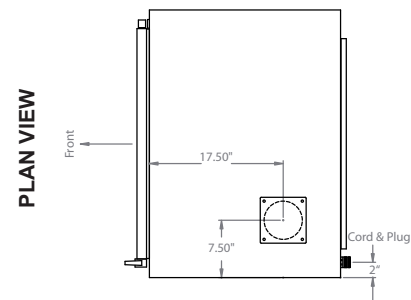
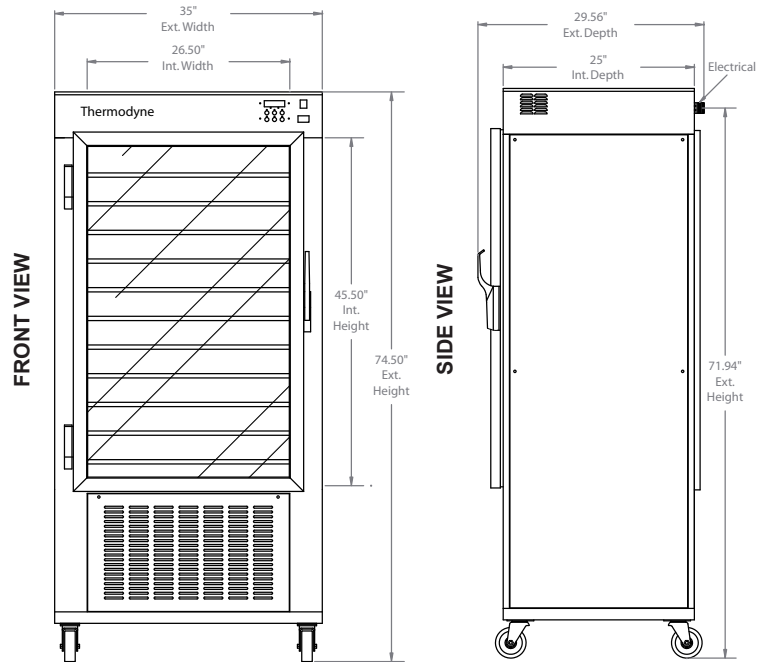

11/09 Patented