

Designed as a dimensional alternative to the 1200G, Thermodyne's 1200DW offers additional space for side by side pan placement along with double doors for tight areas that require a narrow door swing. The 1200DW offers all of the benefits of Fluid Shelf® technology in a compact single stack unit and can be ordered with an optional base extension.



SPECIFICATIONS	
EXTERIOR DIMENSIONS	30.50"W x 25.88"D x 42.75"H
INTERIOR DIMENSIONS	26.50"W x 22.50"D x 29.25"H
CUBIC CAPACITY	10.09ft ³
MAX OPERATING TEMP	230°F
NET WEIGHT	249lbs.
SHIPPING WEIGHT	360lbs.

ELECTRICAL SPECIFICATIONS	
VOLTS	208 / 240
AMPS	25 / 29
TOTAL WATTS	5250 / 7000
HERTZ	60
PHASE †	1
PLUG	NEMA L14-30

SHELVES	
STANDARD	5

CAPACITIES	STANDARD	MAXIMUM*
SHEET PAN		
18" x 26" x 1"	5	10
STEAM TABLE PAN		
12" x 20" x 2.5"	10	14
12" x 20" x 4"	10	10

*Maximum capacities are based on additional shelving. Capacities vary depending on shelf quantities, spacing, and pan depth.

OPTIONS / ACCESSORIES	
Protective Bumper Base	Additional Heat Transfer Plates
Extension Base	Solid Stainless Steel Doors
Solid Back Panel	Stainless Steel Drip Pan

† Available in 3Ø by request

Specifications subject to change without notice.

FRONT VIEW

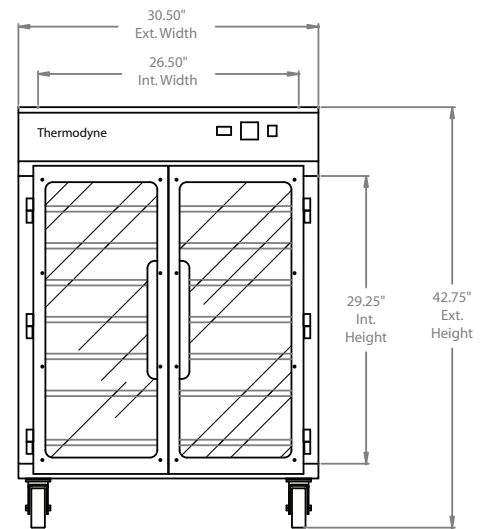

SIDE VIEW

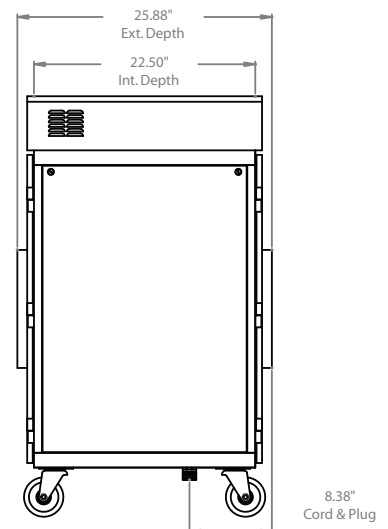

PLAN VIEW

