

Thermodyne's 200CT counter-top holding unit provides food quality and kitchen efficiency like no other piece of equipment on the market today. Using patented Fluid Shelf® technology each shelf in the cabinet maintains an exact temperature, allowing for extended holding times, without sacrificing appearance or taste. This compact unit operates on a simple 120V connection and is available as pass through or with a solid panel back.



SPECIFICATIONS	
EXTERIOR DIMENSIONS	17.50"W x 24.75"D x 20.00"H
INTERIOR DIMENSIONS	13.50"W x 22.00"D x 13.00"H
CUBIC CAPACITY	2.23ft ³
MAX OPERATING TEMP	230°F
NET WEIGHT	103lbs.
SHIPPING WEIGHT	160lbs.

ELECTRICAL SPECIFICATIONS	
VOLTS	120
AMPS	15
TOTAL WATTS	1750
HERTZ	60
PHASE	1

SHELVES	
STANDARD	3

CAPACITY	
STEAM TABLE PAN	
12" x 20" x 2.5"	3

OPTIONS / ACCESSORIES	
High Temp Pans	Vented Stainless Drawer Lids
Controller Shield	Stainless Steel Drip Pan
Pass-thru	Stainless Drawer Lids
Wire Baskets	Stainless Steel Riser

200NDNL - No doors. Includes floating lid system.	
EXTERIOR DIMENSIONS	17.50"W x 23.00"D x 18.63"H
NET WEIGHT	102lbs.
SHIPPING WEIGHT	155lbs.

Specifications subject to change without notice.

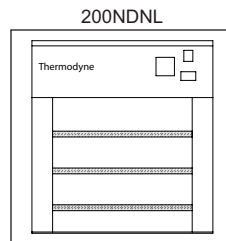

FRONT VIEW

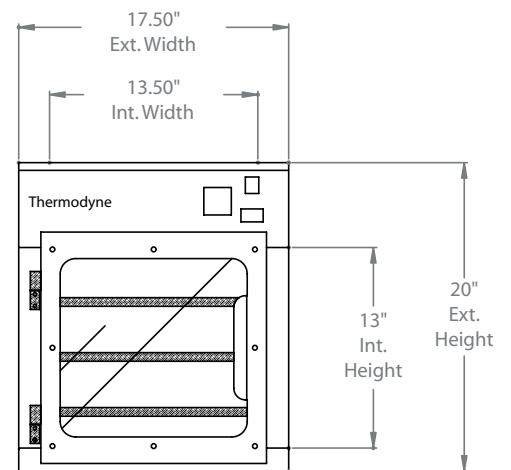

SIDE VIEW

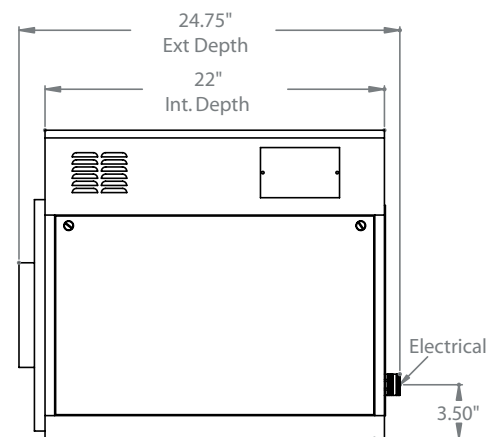

PLAN VIEW

